

Intel® Core™ i7 Processor (32nm) Dual PMC/XMC Carrier



APPLICATIONS

The PP 712/08x is a PC-compatible, high performance, high functionality, CompactPCI® board supporting the Intel® Core™ i7 processor up to 2.53 GHz (32nm process technology), the Mobile Intel® QM57 Express chipset and up to 8 Gbytes of DDR3-1066 ECC SDRAM. This single slot board features 2 PMC/XMC sites and a variety of interfaces including an option for an on-board SATA300 drive and CompactFlash™. The PP 712/08x will operate in a system slot, a peripheral slot or independently from

the CompactPCI bus. System networking is provided by three Gigabit Ethernet links, and the board is compliant to the PICMG® 2.16 specification. Full system monitoring is provided by the PICMG 2.9 compliant IPMI interface. Many suitable industry standard operating systems are supported. The board is plug compatible with the popular PP 512/06x family. The PP 712/08x is suitable for a range of applications within the industrial control, telecomms, telemetry, scientific and aerospace markets.

HIGHLIGHTS

- 2.53 GHz, 2.0 GHz or 1.33 GHz Intel® Core™ i7 processor:
 - dual-core processor
 - 1066MHz DRAM Bus (800 MHz for 1.33 GHz processor)
 - 4 Mbytes shared last level cache
 - Intel® Hyper-Threading Technology
 - Intel® Turbo Boost technology
 - Intel® 64 Technology (64-bit computing support)
- Up to 8 Gbytes of dual channel DDR3-1066 ECC SDRAM
- 4 x High performance SATA300 interfaces plus optional on-board SATA300 drive
- Onboard CompactFlash™ site
- 2 x PMC/XMC module sites with front and rear user I/O:
 - each PMC site 64-bit; 133MHz PCI-X
 - each XMC interface x8 PCI Express™
 - optional Pn6 to Pn6 high speed interconnection bus
- 3 x 10/100/1000Mbps Ethernet interfaces:
 - dual Gigabit Packet Switching Backplane (PICMG 2.16)
- Graphics interfaces via front panel:
 - dual DVI-D interfaces
 - analog video interface
- 2 x serial channels and 5 x USB 2.0 interfaces
- High definition stereo audio
- CompactPCI controller:
 - operates in system slot or peripheral slot
 - 32/64-bit at 33/66 MHz CompactPCI interface
- Option to disable CompactPCI bus (Satellite Mode)
- IPMI (Intelligent Platform Management Interface):
 - PICMG 2.9 (System Management Specification)
- Watchdog timer and Long Duration Timer
- 8 Mbytes of BIOS Flash EPROM
- Extended temperature versions (E-Series, K-Series):
 - E: -25°C to +70°C, air-cooled
 - K: -40°C to +85°C, humidity sealant, air-cooled
 - supporting 2.0 GHz or 1.33 GHz processor
- Support for Linux®, Windows® 7, Windows® Embedded Standard 7, Windows® XP, Windows® XP Embedded, Windows® Server 2003, Windows® Server 2008, VxWorks®, QNX® and Solaris™
- Single slot (for all option combinations)
- Optional Rear Transition Module available:
 - option for USB Flash disk
 - compatible with PP 512/06x family

Specification

Central Processor

- 2.53 GHz Intel® Core™ i7-610E processor, 2.0 GHz Intel® Core™ i7-620LE processor or 1.33 GHz Intel® Core™ i7-660UE processor
- common processor features are:-
 - 32nm process technology
 - dual-core processor
 - 4 Mbytes shared last level cache
 - Intel® Hyper-Threading Technology
 - Intel® 64 Technology (64-bit computing)
 - Intel® Turbo Boost technology
 - uses Ball Grid Array package
- processor to DRAM memory, bus speed:-
 - 610E and 620LE - 1066MHz
 - 660UE - 800MHz
- graphics engine, core clock speed:-
 - 610E - 500MHz
 - 620LE - 266MHz
 - 660UE - 166MHz
 - Intel Turbo Boost technology allows faster graphics engine speed depending on the CPU loading
- utilizes Intel® Platform Controller Hub (PCH):-
 - Mobile Intel® QM57 Express chipset

SDRAM

- up to 8 Gbytes DDR3-1066 ECC SDRAM:-
 - via two SODIMM sockets
 - single bit error correction
 - peak bandwidth of 17 Gbytes/s
 - dual channel architecture
- accessible from processor and CompactPCI bus

Mass Storage Interfaces

- 1 x EIDE interface supports on-board CompactFlash™ socket
- 4 x external Serial ATA300 interfaces:-
 - transfer rate up to 300 Mbytes/s
- optional on-board 2.5 inch SATA300 disk drive
- optional USB Flash disk on Transition Module

Ethernet Interfaces

- 3 x Gigabit Ethernet interfaces
- front panel interface implemented by Intel® 82577 via x1 PCI Express™ link via RJ45
- 2 x rear interfaces implemented by Intel® 82574L controllers via x1 PCI Express link:-
 - support for PICMG® 2.16 R1.0 - Packet Switching Backplane (option)
- supports 10 Base-T, 100 Base-TX, 1000 Base-T

PMC/XMC Interfaces

- 2 x PMC sites supporting:-
 - 32/64-bit, 33/66/100/133 MHz PCI/PCI-X
 - 3.3V or 5V PCI signaling
 - separate PCI Express to PCI-X bridges
 - I/O via front and rear panel via Pn4
- 2 x XMC sites supporting:-
 - up to x8 PCI Express link
 - optional Pn6 to Pn6 high speed interconnection bus

Serial Interfaces

- 2 x RS232 serial channels:-
 - 1 x Tx/Rx channel accessed via a 60-way high-density connector on front panel
 - 1 x Tx/Rx channels via Transition Module
- 16550 compatible UARTs
- front panel supports CTS and RTS, and rear panel supports RI, CTS, RTS, DSR, DTR and DCD

Stereo Audio

- Intel® High Definition Audio via J5:-
 - optional codec module on Transition Module

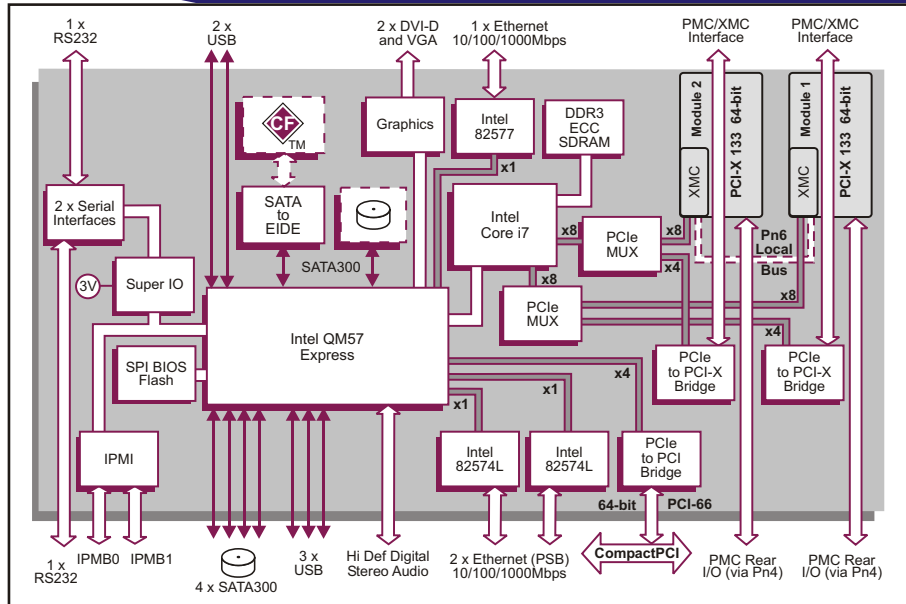

Graphics Interface

- implemented by the integrated chipset graphics controller
- resolutions up to 1920 x 1200 @ 16M colors
- dual digital DVI-D and single analog VGA via front panel:-
 - digital, up to 1600 x 1200 @ 16M colors
 - analog, up to 1920 x 1200 @ 16M colors
- support for Microsoft® DirectX 10
- support for OpenGL 2.0, Windows® and Linux®
- accessed via 60-way high-density connector

Other Peripheral Interfaces

- PC Real Time Clock
- watchdog timer; 32-bit Long Duration Timer with processor interrupt ability; chipset timer
- system fan monitor; CPU temperature monitor; voltages monitor; all accessible via IPMI
- 5 x USB 2.0 interfaces:-
 - 2 accessed via a 60-way high-density connector on front panel
 - 3 interfaces accessed via J5
- independent legacy speaker output via J3

Firmware Support

- UEFI-compliant BIOS with legacy mode support
- comprehensive Power-On Self-Test (POST)
- LAN boot firmware included

Software Support

- support for Linux®, Windows® 7, Windows® Embedded Standard 7, Windows® XP, Windows® XP Embedded, Windows® Server 2003, QNX®, Windows® Server 2008, VxWorks® and Solaris™

Flash EPROM

- 8 Mbytes of BIOS Flash EPROM

IPMI

- PICMG 2.9 R1.0 (System Management Spec.):-
 - implements the IPMB0 interface
 - implements an IPMB1 interface
- on-board Baseboard Management Controller
- supports 8 Kbytes of non-volatile memory

Safety

- PCB (PWB) manufactured with flammability rating of 94V-0

CompactPCI Interface

- compliant with PICMG 2.0 R3.0; 3.3V or 5V signaling levels (universal signaling support)
- 33/66 MHz, 32/64-bit interface accessed via J1/J2 connectors
- PCI Express to PCI bridge for off-board accesses
- J4 connector not fitted
- PICMG 2.1 R2.0 Hot Swap compliant
- operates as System Slot controller or in a Peripheral slot
- option to disable CompactPCI interface (Satellite Mode):-
 - receives power from CompactPCI bus
 - board can be hot swapped

Electrical Specification

- +5V @ 5.7A (typical with 2.53 GHz processor and 4 Gbytes SDRAM); voltage +5%/-3%
- +3.3V @ 5.4A; voltage +5%/-3%
- +12V @ 0.01A; voltage +5%/-5%
- 12V not required
- +12V and -12V routed to PMC/XMC slots

Environmental Specification

- operating temperatures:-
 - 0°C to +55°C (N-Series)
 - -25°C to +70°C (E-Series: 2.0 GHz, 1.33 GHz)
 - -40°C to +85°C (K-Series: 1.33 GHz)
- storage temperature: -40°C to +85°C
- 5% to 95% Relative Humidity, non condensing (operating or storage):-
 - K-Series includes humidity sealant

Mechanical Specification

- 6U form-factor: 9.2-inches x 6.3-inches (233mm x 160mm)
- single-slot: 0.8-inches (20.3mm)
- connectors: IEC-1076-4-101 for J1-J5
- shock: 20g, 11ms, ½ sine
- vibration: 5Hz-2000Hz at 2g, 0.38mm peak displacement

ORDERING INFORMATION

Order Number Product Description (Hardware)

For the order number suffix (xy) options please contact your local sales office: where x = I/O where y = SDRAM size

PP 712/080-xy 1.33 GHz Intel® Core™ i7-660UE processor
 PP 712/082-xy 2.0 GHz Intel® Core™ i7-620LE processor
 PP 712/083-xy 2.53 GHz Intel® Core™ i7-610E processor

x - rear Ethernet configuration and Pn6 option

y - up to 8 Gbytes SDRAM

For accessories please contact your local sales office.
 For extended temperature, E and K-Series, please contact your local sales office.

All companies and product names are trademarks of their respective organizations.
 Specification subject to change; E and OE. RoHS 2002/95/EC compliant.

Datasheet Code 1623/0311
 © Concurrent Technologies 2011